

Trash Pumps

Models: 56200, 562000, 56201, 562001, 56300, 563000, 56301, 563001



Specifically designed pumps for heavy duty applications. Handles solids with ease and simple to open and clean. Standard roll cage protects pump and engine. Steel strainer for intake hose included. Available with Briggs & Stratton Intek Pro™ engine or Honda engines.

Wheeler Rex

3744 Jefferson Road
Ashtabula, OH 44004 USA

www.wheelerrex.com

Phone: 800-321-7950 440-998-2788

Fax: 440-992-2925

Email: wheeler@wheelerrex.com



Features

- ◆ High volume to 300gpm or 1140lpm
- ◆ Comes with epoxy/polyester coated housings
- ◆ Solids handling: 1 inch and 1-1/4 inch spherical solids
- ◆ Steel trash strainer included
- ◆ Roll cage

Pump Specifications	56200 / 56201	56300 / 56301
Suction / discharge ports (inch/mm)	2" / 50	3" / 75
Max Flow (gpm / lpm)	180 / 680	300 / 1140
Max Head (ft / mt)	110 / 33	103 / 31
Max Solids (in / mm)	1" / 2.5	1.25" / 3.2
Max lift (ft / mt)	26 / 8	26 / 8
Priming time / seconds (15 feet or 4.6 meters)	60 / 60	120 / 120

Pump Performance Curves

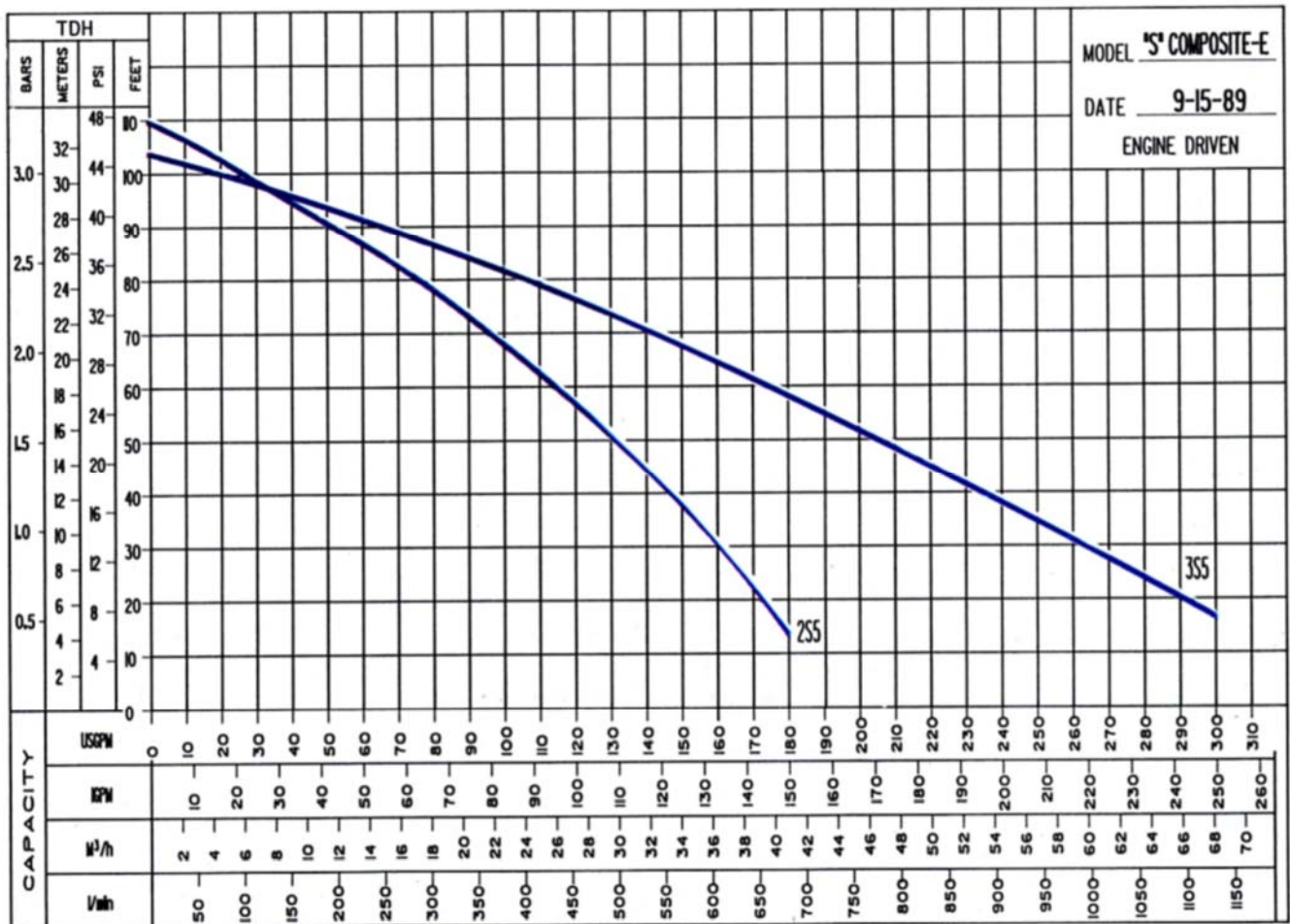

Repair and Maintenance

To disassemble pump follow these steps:

1. Remove handles (9).
2. Remove body (18).
3. Remove the volute (19).
4. Follow these instructions for removing the impeller (2): Remove the impeller by rotating the impeller counter-clock wise. It may be necessary to strike the end of one of the impeller vanes with a wood block and hammer to start the counter-clockwise rotation
5. If the mechanical shaft seal (8) needs replacing:
 - a. With a screwdriver, pry the white seal ring and its rubber boot out of the back of the impeller.
 - b. Remove the pump bracket (rear housing) (13) by removing the four screws (4).
 - c. To remove the seal assembly (8) from the rear housing, drive it out from behind.
6. To replace the seal component in the rear housing, coat the bore in the housing where the seal installs with gasket material (Permatex or equivalent), then press the seal component into the bracket (13) by using an arbor press or drill press. Use a short piece of pipe that fits on the small flange of the seal case so that you are not pressing on the delicate, finely finished seal ring. Do not damage the seal face.
7. To replace the seal component in the impeller hub, lubricate the outside of the rubber boot with vegetable oil, grease or soap and press the white ring and rubber boot into the hub using your two thumbs. Be certain that the seal ring is all the way down and even with the back of the impeller so that the ring does not wobble when the impeller rotates on the shaft. Do not damage the surface of the seal ring.
8. Re-assemble the pump in the reverse manner from the dis-assembly.

Troubles

If difficulties are experienced, in the majority of cases they can be traced to well-known causes. We suggest you check these points first to save needless expense.

If the Pump Falls to Prime:

- A. Make sure that pump casing is full of cool liquid.
- B. If difficulty continues, remove suction hose, start engine and hold a flat piece of rubber sheet, or other suitable material against the suction inlet. If the pump develops a strong pull against the material, the trouble is not in the pump. If there is no pull, the shaft seal may need replacing.
- C. Examine suction hose or pipe connections. Air leaks in the suction line and connection to pump are the most frequent causes of priming trouble. Use new gaskets in hose coupling. New couplings sometimes require 2 gaskets. Lining of hose may also become loose and clog the hose.
- D. Keep pump as close to the level of the liquid being pumped. It will give best performance on suction lifts less than 15 feet, and is not guaranteed to handle any lift over 25 feet at sea level.
- E. Be sure strainer is not clogged.
- F. There are no parts or valves to become clogged or out of adjustment. The only requirement is that the pump case is full of liquid.
- G. Keep your pump unit clean and properly serviced. Care in this respect will repay in many years of trouble-free operation.

Installation and Operation

Inspection - Look over the unit to see that no parts are missing or broken in shipment. An engine instruction book and pump instruction and parts lists are supplied with each pump. Read instruction book carefully.

Placing Pump - Place the pump on a level, firm foundation, putting it as near as possible to the level of the liquid which is to be pumped, but never higher than 25 feet.

Connecting Hose - Connect the hoses or pipes to the suction and discharge fittings. If hose is used, be sure to use strongly reinforced hose on the suction side. Tighten hose couplings firmly using the rubber gaskets furnished with the couplings. Hose or pipes should be supported independently and not carried by the pump.

Before starting:

1. A suction strainer should be attached to the suction hose or pipe. It is provided with holes or slots small enough to prevent big stones etc from damaging the impeller. Keep the strainer clean. If possible, suspend it to keep it from working into the sediment.
2. Fill the engine crankcase with oil as specified in the engine manual.
3. Fill the fuel tank with unleaded gasoline.
4. Fill the pump with liquid through the priming port on top of the pump case. Remember the pumps is self-priming only when the pump is filled. It will prime and re-prime itself without refilling. Refilling is necessary only if pump has been drained or if the fluid has been lost.

Starting - start the engine following instructions in the engine manual.

Warning - Do not use pump in explosive atmosphere. Do not pump volatile or flammable liquids.

Priming Time - With a suction lift from 5 to 10 feet, the pump should discharge liquid in less than a minute. A suction lift of 25 feet (sea level) should require not more than 2 minutes for initial prime. To further reduce priming time, the engine speed may be increased after the engine is properly broken in. If pump does not start within this time, shut off engine and check carefully to find the difficulty. (See Troubles and their Cure).

Control - On high suction lifts, a higher engine speed is necessary than on low lifts. Therefore, on shallow lifts or when there is but little liquid to pump, save fuel and the engine by reducing the engine speed (see engine manual).

Check Valve - If discharge line runs vertically more than 30 feet, it is advisable to install a check valve in the discharge line near the pump to stop destructive liquid hammer when the pump is shut down. If this is done, it may be necessary to vent the top of the pump so that air can be expelled during automatic re-priming. This air bleed may be accomplished by providing a 1/4" line from the top of the pump back to the liquid source. We will no assume any responsibility for damage to the pump if no check valve is used in the discharge line. Properly fueled and lubricated your pump will run without attention.

Draining - During the freezing weather, be sure to drain pump when it is not in use. Unscrew the drain plug and run engine about a half minute without pumping.

Storage - When pump is out of service for long periods, drain it and store in dry well-ventilated room. Pull engine hard against compression so that valves will be sealed. (Never run pump dry for more than half a minute or the shaft seal may be damaged)



WHEELER-REX LIMITED LIFETIME WARRANTY

WHEELER-REX covers its products with a Limited Lifetime Warranty, with exception of pipe threading machines which have a Limited Three Year Warranty (including electric motors). Warranties from manufacturers of components used in our products may pre-empt the Wheeler-Rex warranty. Wheeler-Rex warranties against defects in material or workmanship. To take advantage of this warranty, the complete product must be delivered prepaid to Wheeler-Rex or any WHEELER-REX AUTHORIZED SERVICE CENTER. No tools are to be returned to the factory without receiving prior authorization. Obviously, failures due to misuse, abuse, or normal wear and tear are not covered by this warranty. **NO OTHER WARRANTY, WRITTEN, OR ORAL, APPLIES. THERE ARE NO WARRANTIES WHICH EXTEND BEYOND THE DESCRIPTION ON THE FACE HEREOF.** No employee, agent, dealer, or other person is authorized to give any warranty on behalf of Wheeler-Rex. Warranted products will be repaired or replaced at our option, at no charge and returned to you via prepaid transportation. Such replacement or repair is the exclusive remedy available from Wheeler-Rex. Wheeler-Rex is not liable for damage of any sort, including incidental and consequential damages. Some U.S.A. states do not allow the exclusion or limitation of incidental or consequential damages, so the above limitation or exclusion may not apply. This warranty gives you specific legal rights, and you may also have other rights which vary from state to state.

Form # 1031

WARNING

GENERAL TOOL OPERATION WARNINGS

FOR ALL TOOLS-

1. **Keep Guards in Place** and in working order.
2. **Remove Adjusting Keys and Wrenches** from tool before turning it on.
3. **Keep Work Area Clean.** Cluttered areas and benches invite accidents.
4. **Avoid Dangerous Environment.** Don't use power tools in damp or wet locations. Keep work area well lit. Don't expose power tools to rain.
5. **If you must use an electric tool in a damp or wet location;** make sure it is plugged into a circuit which is protected by a ground fault interrupt.
6. **Keep Children Away. ALL VISITORS SHOULD BE KEPT A SAFE DISTANCE FROM WORK AREA.**
7. **Store Idle Tools** in dry, high, or locked-up place out of reach of children.
8. **Don't Force Tool.** It will do a better and safer job at the rate for which it is designed.
9. **Use Right Tool.** Don't force a small tool or attachment to do the job of a heavy-duty tool.
10. **Wear Proper Apparel.** No loose clothing or jewelry to get caught in moving parts. Rubber gloves and footwear are recommended when working outdoors.
11. **Use Safety Glasses.**
12. **Don't Abuse Cord.** Never carry tool by cord or yank it to disconnect from receptacle. Keep cord from heat, oil, and sharp edges.
13. **Secure Work.** Use clamps or vise to hold work when practical. It's safer than using your hand and it frees both hands to operate tool.
14. **Don't Overreach.** Keep proper footing and balance at all times.
15. **Maintain Tools Properly.** Keep tools sharp and clean for best and safest performance. Follow instructions for lubricating and changing accessories. Equipment operators must have proper maintenance & instruction sheets. Be sure the tool operator reads and understands this information. If you don't have current maintenance and instruction sheets, contact the factory & we will supply them at no charge.
16. **Disconnect Tools** when not in use; before servicing; when changing accessories such as dies, cutters, etc.
17. **Avoid Accidental Starting.** Don't carry plugged-in tool with finger on switch. Be sure switch is off when plugging in.
18. **Outdoor Use Extension Cords.** When tool is used outdoors, use only extension cords suitable for use outdoors and so marked.
19. **Wear Ear Protection** if exposed to long periods of very noisy shop operations.
20. **Do not operate tools** while under the influence of alcohol, drugs or medication.

56200 / 562000

WHEELER
REX

3744 Jefferson Rd., Atterbury, OH 44005
Dodge County, Ohio
27 TRASH PUMP w/ ROLL CAGE
PART NO. 56200

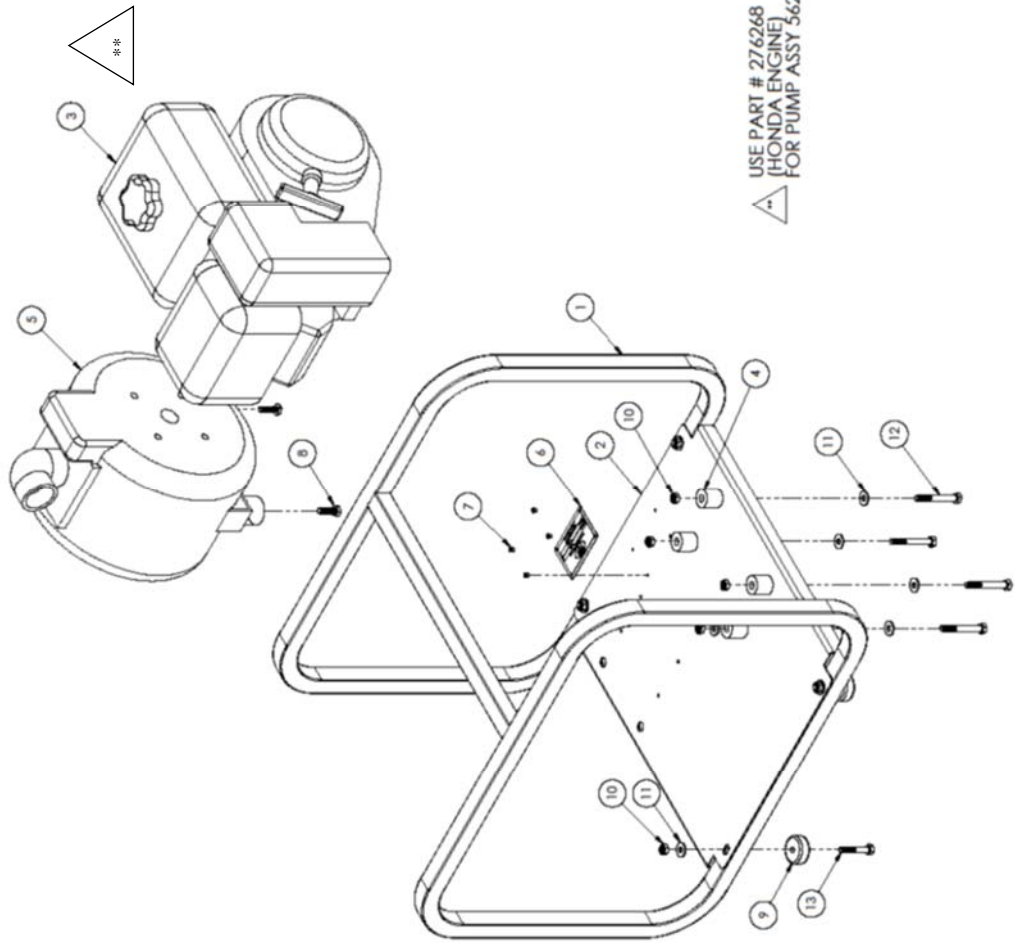

USE PART # 276268
(HONDA ENGINE)
FOR PUMP ASSY 562000

56200 / 562000

Item	Part No	Description 56200	Qty
1	276269	Large Roll Cage	1
2	700942	Base Plate	1
3	276267	5hp B&S Engine	1
4	700892	Spacer	4
5	276266	2" Trash Pump Kit	1
6	220874	Name Plate	1
7	275543	Pop Rivet, Star 4-2AAD	4
8	1020	5/16-18 x 1" Hex Head Cap Screw	2
9	276443	Rubber Foot	4
10	275857	5/16-18 Hex Nylon-Insert Locknut	8
11	275685	5/16" Flat Washer	9
12	276133	5/16-18 x 2-1/2" HHCS	4
13	275639	5/16-18 x 1-3/4" HHCS	4

562001 / 562001

**WHEELER
REX**
2744 Jefferson Rd., Authtsbul, OH 44005
2" TRASH PUMP W/ WHEELED CART
PART NO. 562001

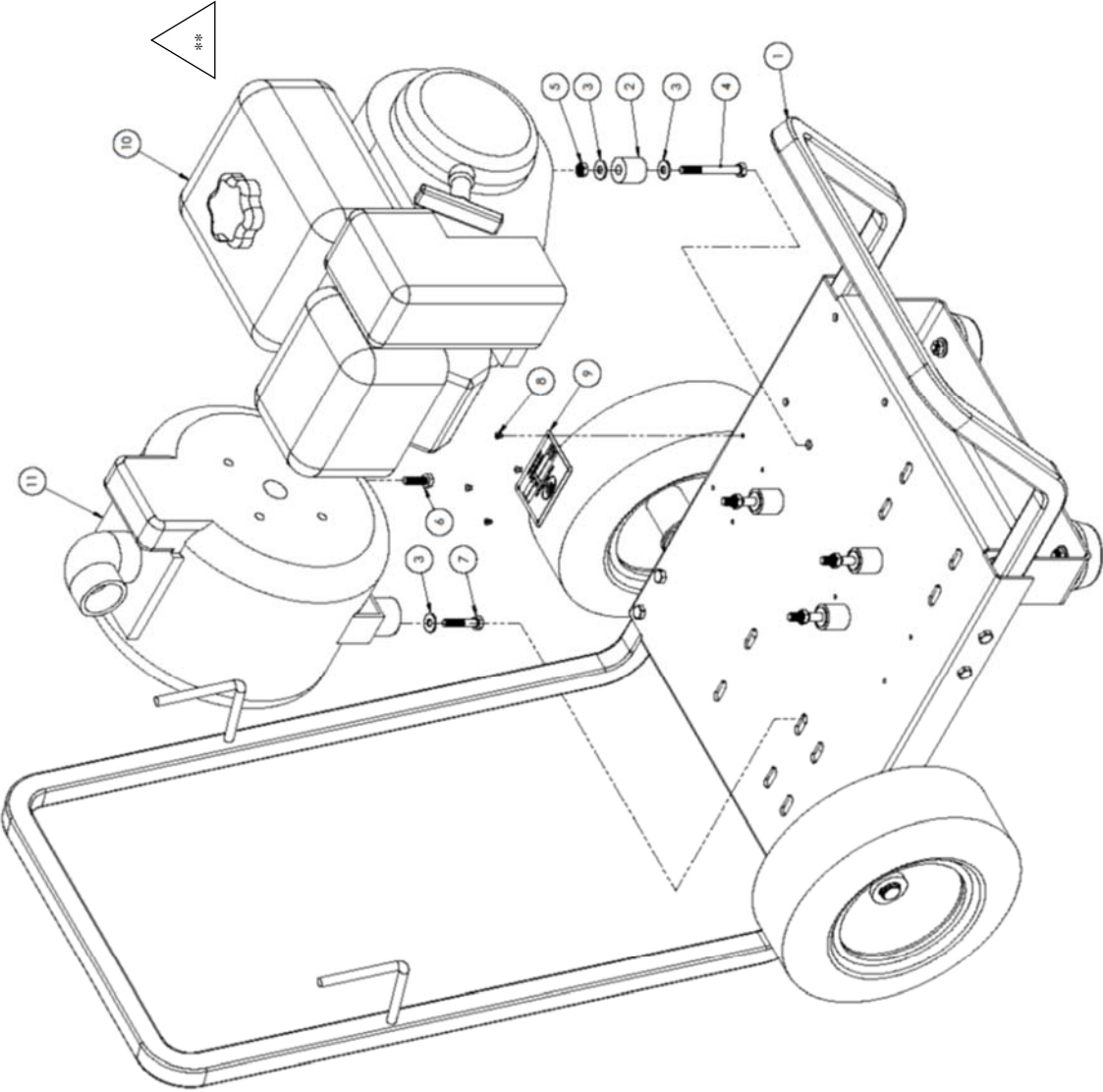

56201 / 562001

Item	Part No	Description	Qty
1	700136	Pump Cart	1
2	700892	Spacer	4
3	275685	5/16" Flat Washer	9
4	276737	5/16"-18x2-3/4" Hex Head Cap Screw	4
5	275857	5/16-18 Hex Nylon-Insert Locknuts	4
6	1020	5/16-18 x 1" Hex Head Cap Screw	1
7	275638	5/16-1-1/2" Hex Head Cap Screw	1
8	275543	Pop Rivet, Star 4-2AAD	4
9	220874	Name Plate	1
10	276268	5hp Honda Engine	1
11	276266	2" Trash Pump Kit	1

56300 / 563000

WHEELER
REX
3744 Johnson Rd., Amherst, OH 44001
DESCRIPTION: 3" TRASH PUMP w/ ROLL CAGE
PART NO. 56300

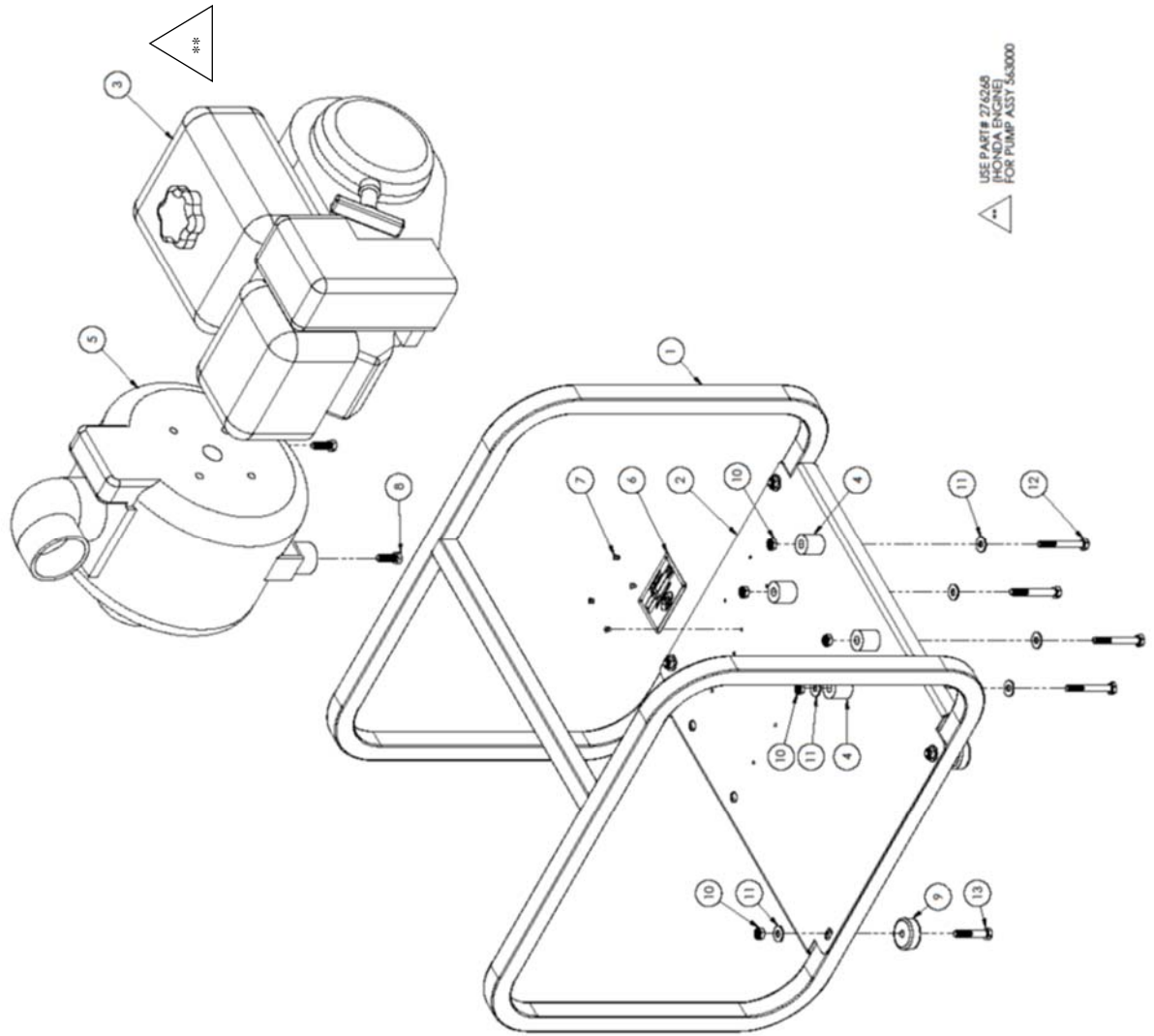

56300 / 563000

Item	Part No	Description 56300	Qty
1	276269	Large Roll Cage	1
2	700942	Base Plate	1
3	276267	5hp B&S Engine	1
4	700892	Spacer	4
5	276265	3" Trash Pump Kit	1
6	220874	Name Plate	1
7	275543	Pop Rivet, Star 4-2AAD	4
8	1020	5/16-18 x 1" Hex Head Cap Screw	2
9	276443	Rubber Foot	4
10	275857	5/16-18 Hex Nylon-Insert Locknut	8
11	275685	5/16" Flat Washer	9
12	276133	5/16-18 x 2-1/2" HHCS	4
13	275639	5/16-18 x 1-3/4" HHCS	4

56301 / 563001

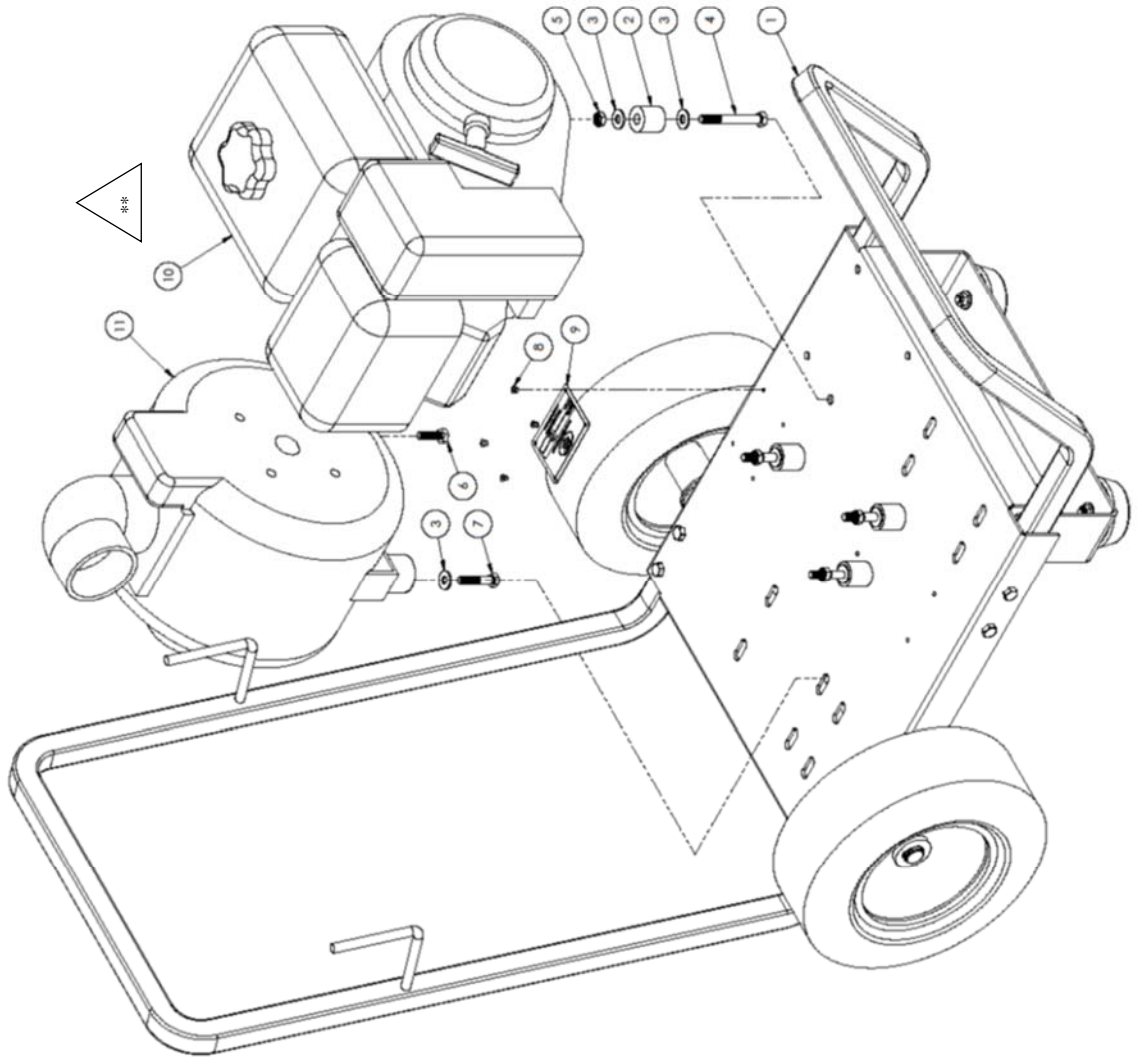

USE PART # 27 6267
(BRIGGS & STRATTON ENGINE)
FOR PUMP ASSY 56301



3114 Jefferson Rd., Ashland, OH 44805
DESCRIPTION: 3' TRASH PUMP W/ WHEELED CART
PART NO. 563001

56300

Item	Part No	Description	Qty
1	700136	Pump Cart	1
2	700892	Spacer	4
3	275685	5/16" Flat Washer	9
4	276737	5/16"-18x2-3/4" Hex Head Cap Screw	4
5	275857	5/16-18 Hex Nylon-Insert Locknuts	4
6	1020	5/16-18 x 1" Hex Head Cap Screw	1
7	275638	5/16-1-1/2" Hex Head Cap Screw	1
8	275543	Pop Rivet, Star 4-2AAD	4
9	220874	Name Plate	1
10	276268	5hp Honda Engine	1
11	276265	3" Trash Pump Kit	1

Internal Pump Parts

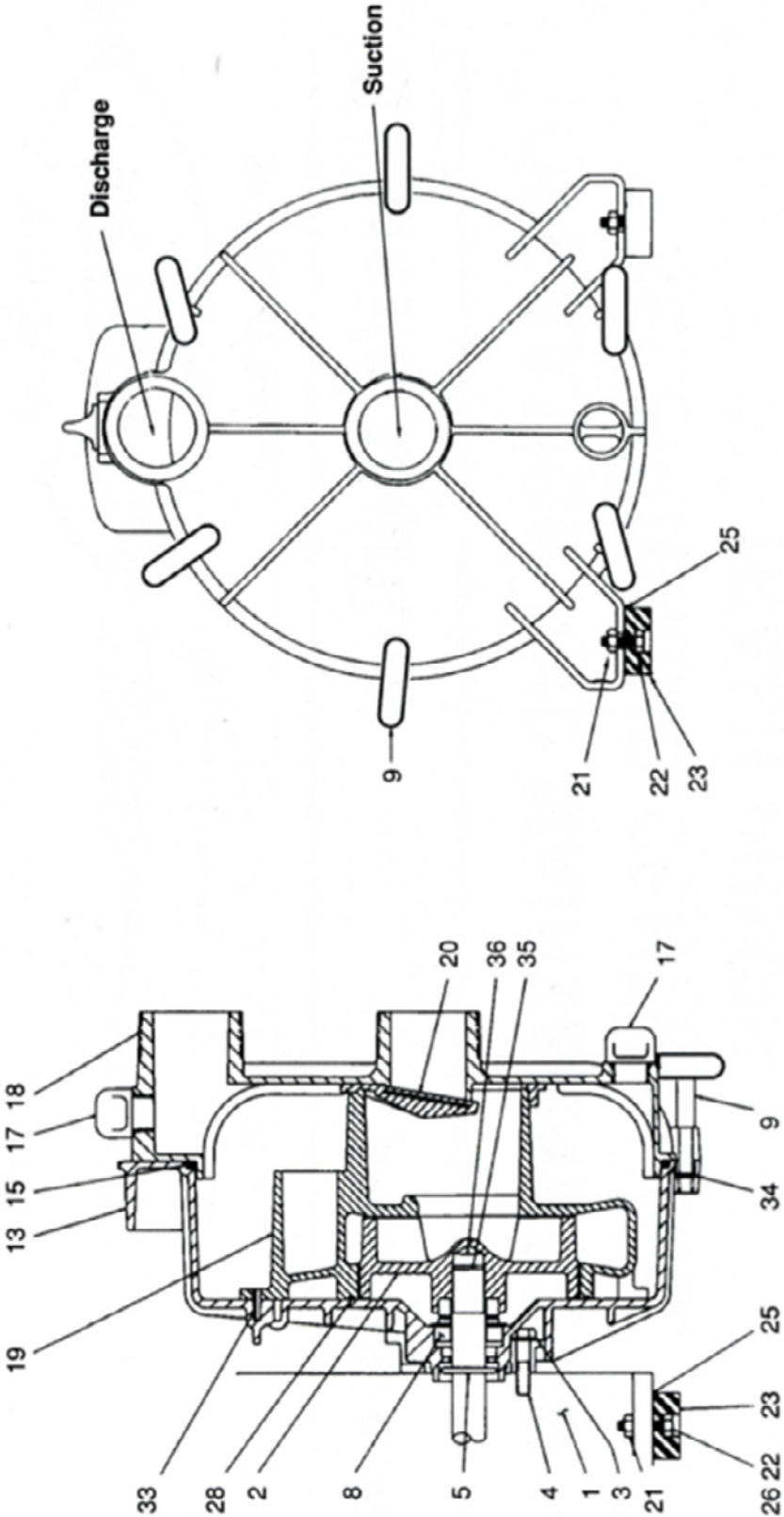

56200 / 562000 / 56210 / 562001

5HP	276268		Engine-Threaded Shaft
5HP	276267		B & S Engine - Threaded Shaft
2-127-A	276484		Impeller
16-233-1	276485	**	Sealing Washer (set of four)
19-216	276486		Bolt 5/16-24 X 1.38 SST
12-117-B	276487		Slinger
3-258-A	276488	**	Shaft Seal, Sic-Viton
32-134	276489		Handle
5-128-2B	276491		Bracket Epoxy
12-133	276472	**	Body O-Ring EPDM (std)
12-133-A	276492		Body O-Ring Viton (alt)
11-116-1	276493	**	Plug & O-Ring EPDM (std)
11-116-1A	276494		Plug & O-Ring Viton (alt)
6-129-2A	276496		Body Epoxy
1-139	276497		Volute
7-136-1	276498	**	Check Valve - EPDM (std)
7-136-1A	276449		Check Valve - Viton (alt)
14-167	276500		Locknuts
19-232	166		Bolts 5/16 -18x3/4"
29-237	276501		Feet, Rubber
15-138	276482		Washer, flat, 5/16 X 1-1/2
19-238	276483		Bolts 5/16 -24x1 3/8"
12-160	276471		O-Ring EPDM
12-160-A	276502		O-Ring Viton
21-298	276503		Roll pin SST
12-299-1	276504		O-Ring retaining (set of 6)
22-255-1A	276505	**	Shim, impeller (set of 4)
23-301-A	276506	**	Spacer, Impeller
44-278	276507		Trash Strainer 2"
50-006	276270		Seal & O-Ring Kit EPDM (std)
50-006-A	276509		Seal & O-Ring Kit Viton (alt)
6-129-1A	276495		Body Roto Finish
<p>** Included in Repair Kit</p>			

56300 / 563000 / 56301 / 563001

5HP	276268		Honda Engine
6.5HP	276267		B & S Engine - Threaded Shaft
2-313-A	276519		Impeller, 3"
16-233-1	276485	**	Sealing Washer (set of four)
19-216	276486		Bolt 5/16-24 X 1.38 SST
12-117-B	276487		Slinger
3-258-A	276488	**	Shaft seal, sic-Viton
32-196	276518		Handle
5-128-1B	276490		Bracket - Roto Finish
5-128-2B	276491		Bracket white epoxy
12-133	276472	**	Body O-Ring EPDM (std)
12-133-A	276492		Body O-Ring Viton (alt)
11-116-1	276493	**	Plug & O-Ring EPDM (std)
11-116-1A	276494		Plug & O-Ring Viton (alt)
6-131-2A	276511		Body Epoxy
1-312	276512		Volute
7-137-1	276513	**	Check Valve EPDM
7-137-1A	276514		Check Valve Viton
14-167	276500		Locknuts
19-232	166		Bolts 5/16 -18x3/4"
29-237	276501		Feet, Rubber
15-138	276482		Washer, Flat, 5/16 X 1-1/2
19-238	276483		Bolts 5/16 -24x1 3/8"
12-160	276471		O-Ring EPDM
12-160-A	276502		O-Ring Viton
21-298	276503		Roll Pin SST
12-299-1	276504		O-Ring retaining (set of 6)
22-255-1A	276505	**	Shim, impeller (set of 4)
23-301-A	276506	**	Spacer, impeller
44-314	276515		Trash Strainer
50-007	276271		Seal & O-Ring kit EPDM (std)
50-007-A	276517		Seal & O-Ring kit Viton (alt)
6-131-1A	276510		Body Roto Finish

** Parts included in Repair Kit



[The main body of the page is blank white space, framed by a thin blue border.]

Wheeler Rex

3744 Jefferson Road
Ashtabula, OH 44004 USA

www.wheelerrex.com

Phone: 800-321-7950 440-998-2788
Fax: 440-992-2925
Email: wheeler@wheelerrex.com

